

Designation of a locknut
with $d_1 = M 40 \times 1,5$:
Locknut MSR 40 x 1,5

MSR	Dimensions in mm									Clamping screws			Calculation factor A mm	Locknut-specific allowance B N	Adm. axial operating stress		Mass moment of inertia J kg cm ²
	d ₁	d ₂	d ₃ ¹⁾	d ₄	d ₅ ¹⁾	d ₆	h	l	e	ISO 4762	M _A	No.			dyn.	stat.	
ISO - 5H	h11	H11															
10 · 0,75	24	2,5	17	3,2	22	14	3	6,5	M3	2	3	0,672	2457	12	16	0,025	
10 · 1	24	2,5	17	3,2	22	15	3	6,5	M3	2	3	0,703	2457	12	15	0,027	
12 · 1	26	3	19	3,2	25	14	3	6,5	M3	2	3	0,819	2438	14	19	0,037	
12 · 1,5	26	3	19	3,2	25	15	3	6,5	M3	2	3	0,881	2438	13	18	0,040	
14 · 1,5	32	4	22,5	4,3	30	16	3	7	M4	2,9	3	0,997	2995	17	22	0,096	
15 · 1	33	4	23,5	4,3	31	16	3	7	M4	2,9	3	0,992	2984	19	25	0,108	

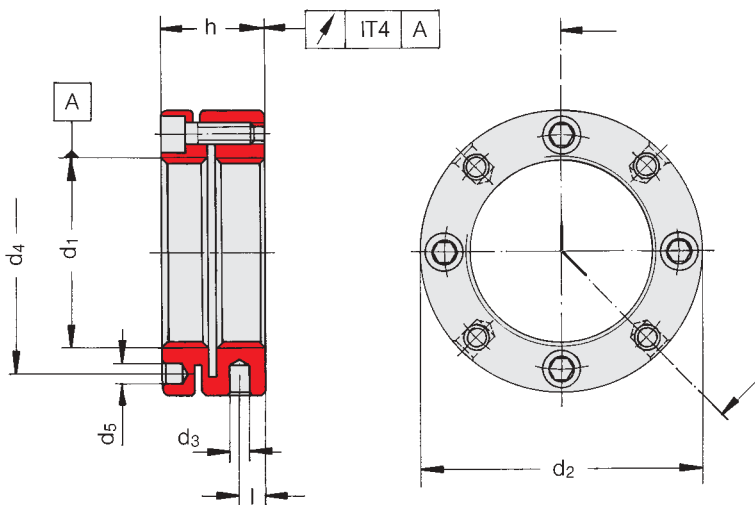

The admissible operating loads specified in the table are guideline values calculated with a safety factor of 1.6
 – under static stress relative to the minimum yield point,
 – under dynamic stress relative to the minimum alternate strength.

Subject to changes.
 Special versions:
 On request, by sending of an explanatory sketch.

MSR	Dimensions in mm							Clamping screws			Calculation factor A mm	Locknut-specific allowance B N	Adm. axial operating stress		Mass moment of inertia J kg cm ²
	d ₁	d ₂	d ₃ ¹⁾	d ₄	d ₅ ¹⁾	h	l	ISO 4762	M _A	No.			dyn.	stat.	
ISO - 5H	h11	H11													
16 · 1,5	34	4	24,5	4,3	18	5	M4	2,9	4	1,112	3962	17	22	0,147	
17 · 1	35	4	25,5	4,3	18	5	M4	2,9	4	1,108	3947	19	25	0,164	
18 · 1,5	36	4	26,5	4,3	18	5	M4	2,9	4	1,228	3931	19	25	0,183	
20 · 1	40	4	30,5	4,3	18	5	M4	2,9	4	1,281	3900	22	29	0,283	
20 · 1,5	40	4	30,5	4,3	18	5	M4	2,9	4	1,344	3900	18	28	0,283	
22 · 1,5	40	4	30,5	4,3	18	5	M4	2,9	4	1,459	3869	23	32	0,270	
24 · 1,5	42	4	32,5	4,3	18	5	M4	2,9	4	1,575	3838	25	35	0,323	
25 · 1,5	45	5	36,5	4,3	20	6,5	M4	2,9	4	1,633	3822	33	47	0,488	
26 · 1,5	45	5	36,5	4,3	20	6,5	M4	2,9	4	1,690	3806	34	49	0,479	
28 · 1,5	46	5	38,5	4,3	20	6,5	M4	2,9	4	1,805	3775	36	53	0,504	
30 · 1,5	48	5	40,5	4,3	20	6,5	M4	2,9	4	1,921	3744	38	57	0,588	
32 · 1,5	50	5	42,5	4,3	22	7	M4	2,9	4	2,037	3713	44	64	0,743	
35 · 1,5	53	5	45,5	4,3	22	7	M4	2,9	4	2,210	3666	47	66	0,914	
38 · 1,5	58	5	48,5	4,3	22	7	M4	2,9	4	2,449	3619	50	75	1,337	

